

Universal valve construction

The electromagnetic force produced in the coil lifts the seal from the orifice. This type of valve does not rely on a pressure drop. Non energised closed by spring power.



type of control:	direct acting	metallic internals:	brass and stainless steel (AISI 430F)
construction:	poppet design	seal:	NBR
connection:	G1/4-G2, DIN ISO 228	installation:	actuator only in upright position
Druck: pressure:	0-20 bar (s. Tabelle) 0-20 bar (see table)	Anschlußspannung: supply voltage:	AC: 24,42,110,230V 50/60Hz DC: 24,110,205V=
Durchflußmedium: medium:	neutrale, gasförmige u. flüssige Medien neutral, gaseous and liquid fluids	Spannungstoleranz: voltage tolerance:	+5% / -10% +5% / -10%
Viskosität: viscosity:	22mm ² /s 22mm ² /s	Leistungsaufnahme: power-consumption:	1322/3322 = 30 Watt 4242/5242 = 46 Watt 4272/5272 = 100 Watt 4352/5352 = 150 Watt
Mediumtemperatur: medium temperature:	-10 bis +80°C -10 up to +80°C	Schutzart: enclosure standard:	IP65 nach DIN 40050 IP65 according to DIN 40050
Umgebungstemperatur: ambient temperature:	+35°C +35°C	Einschaltdauer: operating factor:	100%ED-VDE 0580 100%ED-VDE 0580
Ventilgehäuse: body material:	/10../.. = Messing /10../.. = brass	Kabelanschluß: electric connection:	Gerätestecker DIN 43650 / Klemmkasten DIN 43650 - plug / terminal box

Wirkungsweise als Mehrzweckventil wahlweise:

- 2/2-Wege Ventil, NC in Ruhestellung geschlossen, Druckanschluß 1 (P), Anschluß 3 (R) verschlossen
- 2/2-Wege Ventil, NO in Ruhestellung geöffnet, Druckanschluß 3 (R), Anschluß 1 (P) verschlossen
- als Umsteuerventil mit einem Zugang, Druckanschluß 2 (A), Anschluß 1 (P) und 3 (R) Abgang
- als Umsteuerventil mit zwei Zugängen, Druckanschluß 1 (P) und 3 (R), Anschluß 2 (A) Abgang
- 3/2-Wege Ventil, NC in Ruhestellung geschlossen, Druckanschluß 1 (P), Anschluß 2 (A) Abgang, Anschluß 3 (R) Entlastung
- 3/2-Wege Ventil, NO in Ruhestellung geöffnet, Druckanschluß 1 (P), Anschluß 2 (A) Abgang, Anschluß 3 (R) Entlastung

as multi function valve alternatively:

- 2/2-way valve, NC normally closed, pressure inlet 1 (P), connection 3 (R) closed
- 2/2-way valve, NO normally open, pressure inlet 3 (R), connection 1 (P) closed
- valve universal function with one inlet, pressure inlet 2 (A), exit 1 (P) and 3 (R)
- valve universal function with two inlets, pressure inlet 1 (P) and 3 (R), exit 2 (A)
- 3/2-way valve, NC normally closed, pressure inlet 1 (P), outlet 2 (A), exit 3 (R)
- 3/2-way valve, NO normally open, pressure inlet 1 (P), outlet 2 (A), exit 3 (R)

G	Sitz orifice mm	Kv-Wert flow-rate m ³ /h	Standardtype standard type	max. Druck bei Magnettype max. pressure range reagrding solenoid type			
				.322	.242	.272	.352
1/4	11	0,8	A7321/1001/....	0-10	0-20	-	-
3/8	11	1,0	A7322/1001/....	0-10	0-20	-	-
1/2	11	1,2	A7323/1001/....	0-10	0-20	-	-
3/4	22	5,3	A7324/1001/....	0-1	0-10	0-20	-
1	22	5,3	A7325/1001/....	0-1	0-10	0-20	-
5/4	32	21,0	B7326/1001/....	-	0-1	0-10	0-15
6/4	32	21,0	B7327/1001/....	-	-	0-10	0-15
2	40	29,0	B7328/1001/....	-	-	0-3	0-8

Maßzeichnung Standardausführung
dimensional drawing of standard type

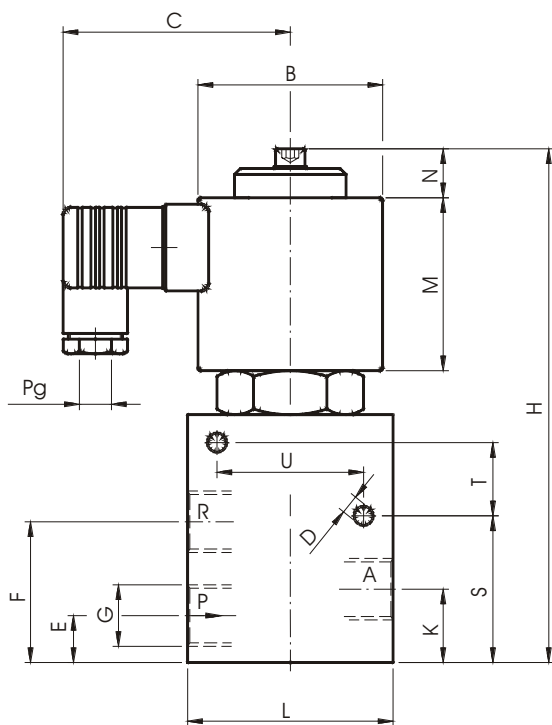

Schaltfunktion / function:

in Ruhestellung geschlossen
in rest-position closed-NC



in Ruhestellung geöffnet
in rest-position open-NO.

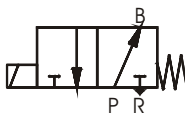

mischen / mixing

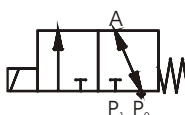

verteilen / distribute

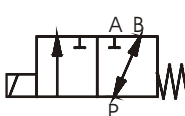

Anschlußplan / connection diagramm

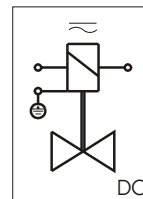

Für Gleichspannung.
For DC.

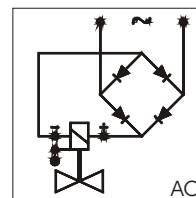

Mit vorgeschaltetem Gleichrichter
für Wechselspannung.
With integrated rectifier for alternating

Erdung oder Schutzschaltung nach Vorschrift des zuständigen EVU.
Grounding or earthing of the protective circuit in accordance with regulations of the responsible electric supply company.

Absicherung entsprechend der Stromaufnahme vorsehen.
Appropriate protection according to the power-consumption.

Magnet solenoid	.322		.242			.272			.352	
Type	7321-23	7324-25	7321-23	7324-25	7326-27	7324-25	7326-27	7328	7326-27	7328
G	1/4-1/2	3/4-1	1/4-1/2	3/4-1	5/4-6/4	3/4-1	5/4-6/4	2	5/4-6/4	2
A=Breite	40	70	40	70	100	70	100	112	100	112
B	63	63	77	77	77	105	105	105	145	145
C	76	76	82	82	82	95	95	95	120	120
D	6,5	6,5	6,5	6,5	8,5	6,5	8,5	-	8,5	-
E	16	23	16	23	33	23	33	40	33	40
F	48	80,5	48	80,5	117	80,5	117	142	117	142
H	180	250	235	240	310	300	310	390	400	430
K	25	23	25	23	33	23	33	40	33	40
L	70	95	70	95	132	95	132	160	132	160
M	59	59	70	70	70	90	90	90	144	144
N	20	20	20	20	20	25	25	25	15	15
S	50	80,5	50	80,5	118	80,5	118	-	118	-
T	25	25	25	25	35	25	35	-	35	-
U	50	50	50	50	70	50	70	-	70	-
Pg	11	11	13,5	13,5	13,5	13,5	13,5	13,5	13,5	13,5
kg	3,0	4,9	4,5	6,2	12,5	9,7	16	20,5	25,5	30

Alle Angaben sind freibleibend und unverbindlich / all technical specifications are without obligation!

Weitere Ventilausführungen /

Dichtung= FKM, EPDM, PTFE
seal= FKM,EPDM,PTFE

andere Durchflußmedien und Viskositäten
varying medium and viscosity ranges

abweichende Temperaturen und Drücke
varying temperature and pressure ranges

Ventilgehäuse= Edelstahl und Rotguß
valve housing= stainless steel and red brass

Stellungsanzeiger (Endschalter)= EH
position indicator (limit switch)= EH

optional extras

Handbetätigung= HA
manual override= HA

Halbautomatik= HU
semi automatic= HU

Öl- und fettfrei= OF
free of oil and grease= OF (for oxygen applications)

buntmetallfrei= BF
free of brass and bronze=BF

Ex-Schutz= EEx emII T4, EEx dII cT6
explosion proof= EEx emII T4, EEx dII cT6

Stückliste - parts list

- K1.1 Armatur / valve body
- K3.1 Einsatz / inset
- K3.2 Scheibe / disk
- *K3.3 Spindel / spindle
- *K3.4 Ventilteller / valve plate
- *K3.5 O-Ring / o-ring
- *K3.6 O-Ring / o-ring
- *K3.7 O-Ring / o-ring
- *K3.8 O-Ring / o-ring
- K3.9 Befestigungsmutter / locking nut
- K3.10 Gewindestift / grub screw
- *K3.11 Feder / spring
- K5.1 Magnethülse / solenoid tube
- K5.2 Magnetanker / solenoid plunger
- K5.3 Scheibe / disk
- K5.4 O-Ring / o-ring
- K5.5 O-Ring / o-ring
- K5.6 Druckstück / pressure part
- K5.7 Zylinderschraube / cylinder screw
- K5.8 Sicherungsscheibe / locking disk
- K6.1 Magnetspule / solenoid
- K7.1 Stecker o. Klemmkasten / plug or terminal box

* = Bestandteil des Ersatzteilkäppchens
(je nach Ausführung freibleibend)
 * = all components of spare parts and service sets are variable in reference to different versions and executions. (These specifications are without obligation).

Baureihe / type A7321-A7323
 Standardausführung / standard type

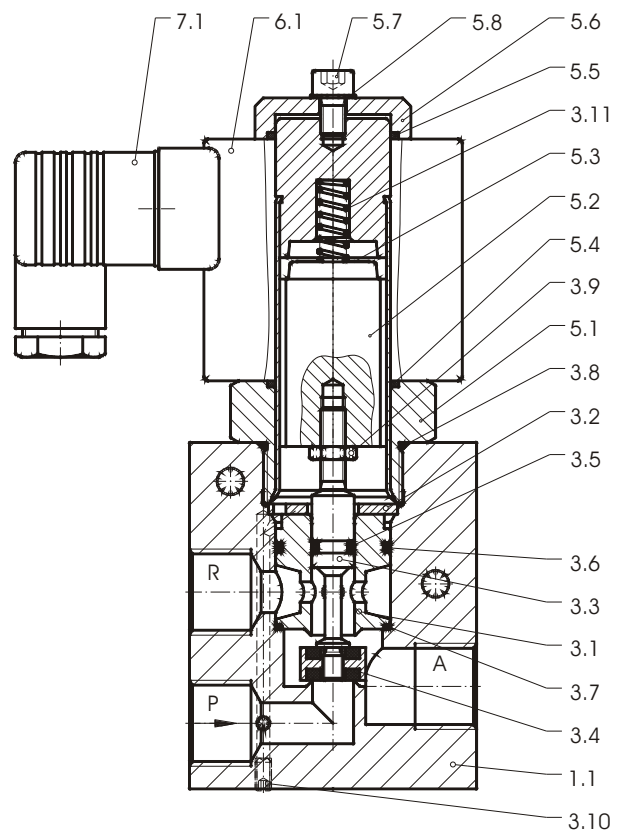

Stückliste - parts list

- K1.1 Armatur / valve body
- K3.1 Zwischenstück / intermediate piece
- K3.2 Führungsstern / guide star
- *K3.3 Ventilteller / valve plate
- *K3.4 Spindel / spindle
- *K3.6 O-Ring / o-ring
- *K3.7 O-Ring / o-ring
- *K3.9 O-Ring / o-ring
- K3.10 Befestigungsmutter / locking nut
- *K3.13 Feder / spring
- K5.1 Magnethülse / solenoid tube
- K5.2 Magnetanker / solenoid plunger
- K5.3 Druckstück / pressure part
- K5.4 O-Ring / o-ring
- K5.5 O-Ring / o-ring
- K5.6 Druckstück / pressure part
- K5.7 Zylinderschraube / cylinder screw
- K5.8 Sicherungsscheibe / locking disk
- K6.1 Magnetspule / solenoid

* = Bestandteil des Ersatzteilkäppchens
(je nach Ausführung freibleibend)
 * = all components of spare parts and service sets are variable in reference to different versions and executions. (These specifications are without obligation).

Baureihe / type A7324-B7328
 Standardausführung / standard type

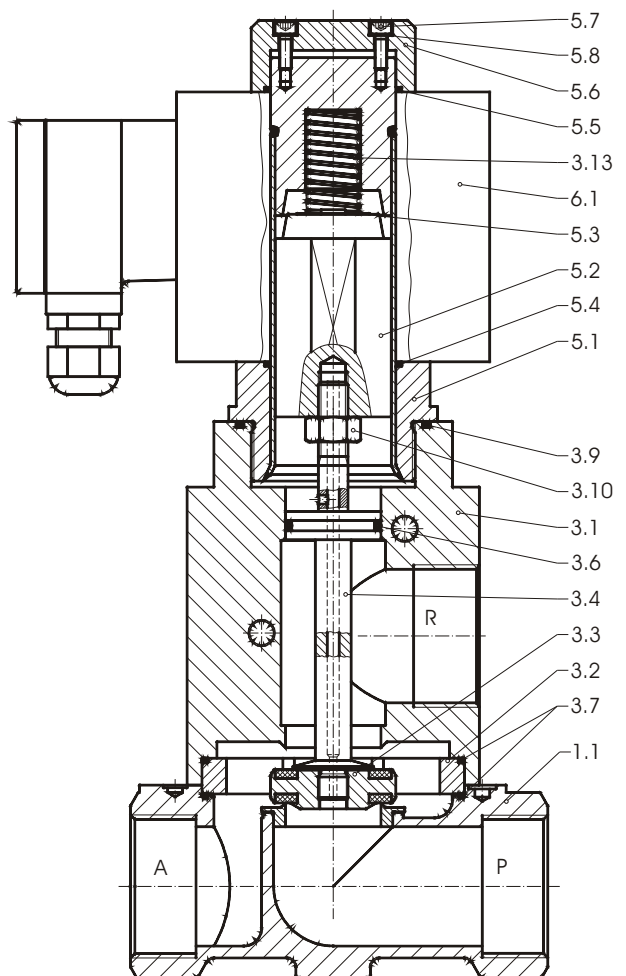

Ventiloptionen / optional extras

Stückliste - parts list

- K1.1 Armatur / valve body
- K3.1 Zwischenstück / connector
- K3.2 Führungsstern / guide star
- *K3.3 Spindel / spindle
- *K3.4 Ventilteller / valve plate
- *K3.5 O-Ring / o-ring
- *K3.6 O-Ring / o-ring
- *K3.7 O-Ring / o-ring
- *K3.8 Befestigungsmutter / locking nut
- *K3.11 Feder / spring
- K3.12 Verschraubung / screw joint
- K3.13 Schaltmagnet / magnet
- K3.14 Gewindestift / thread pin
- *K3.15 O-Ring / o-ring
- K3.16 Verschraubung / screw joint
- K3.17 Befestigungsmutter / locking nut
- K3.18 Verschraubung / screw joint
- K3.19 Endschalter / position indicator
- K6.1 Magnetspule / solenoid

*= Bestandteil des Ersatzteilpäckchens
(je nach Ausführung freibleibend)

*= all components of spare parts and service sets are variable in reference to different versions and executions. (These specifications are without obligation).

Baureihe 73 Ausführung mit EEx emII T4/
type 73 EEx emII T4-design

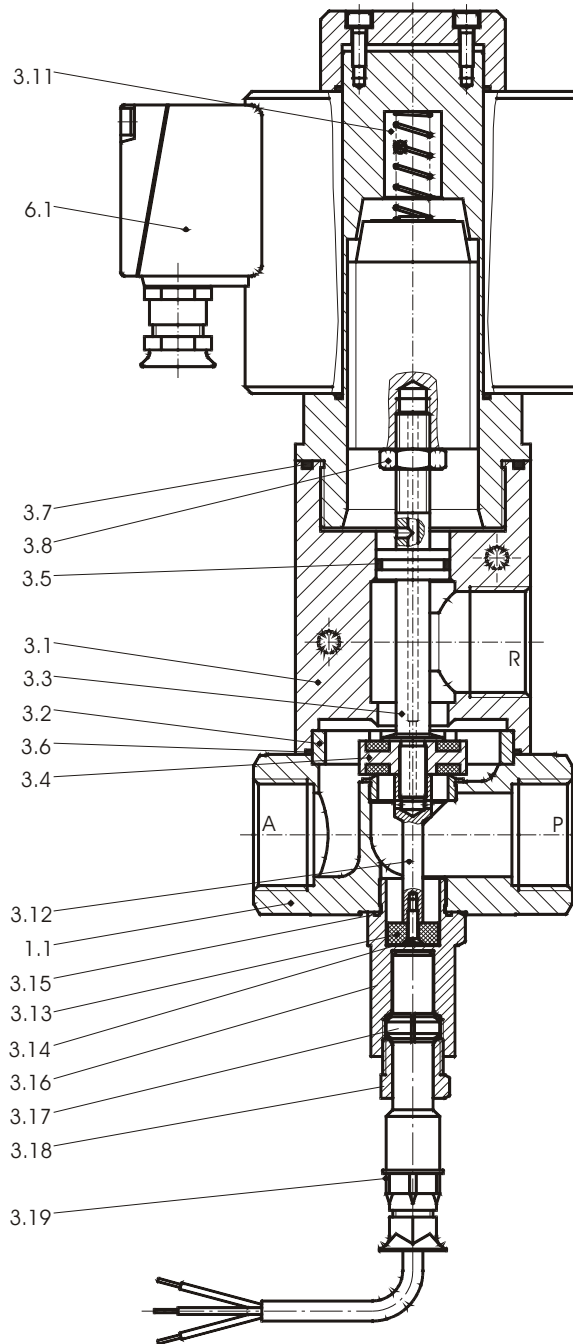

GSR

Ventiltechnik
GmbH & Co. KG